



ROCKCRETE

EQUIPMENT (PTY) LTD

Company Reg. No: 1947/024677/07

OPERATORS MANUAL

FOR

ROCKCRETER C70A



SOUTH AFRICAN SHOTCRETE TECHNOLOGY
Designed to perform, the power to succeed!

P. O. Box 18924 Sunward Park 1470 • 13 Log Road, Roodekop, Germiston, South Africa
Co. Reg. no: 1947/24677/07

TEL: (+2711) 865 3019 FAX: (+2711) 865 1346

e-mail: information@rockcrete.co.za

www.rockcrete.co.za

As part of our policy of constant product development and improvement information and specifications contained in this document are liable to change.

**OPERATORS MANUAL
FOR
ROCKCRETER C70A**



Intentionally Left Blank

CONTENTS LIST

| Figure | Description | Page No |
|--------|-----------------------------|---------|
| 1. | SAFETY PROCEDURES | 1 |
| 2. | TECHNICAL SPECIFICATIONS | 2 |
| 3. | PRINCIPLES OF OPERATION | 2 |
| | 3.1 Materials | 3 |
| | 3.2 Flow | 3 |
| | 3.3 Setting Time | 3 |
| | 3.4 Pumping Distance | 3 |
| | 3.5 General Procedures | 4 |
| 4. | OPERATING PROCEDURES | 6 |
| | 4.1 Set-Up | 6 |
| | 4.2 Start-Up | 6 |
| | 4.3 Production | 7 |
| | 4.4 Clean-Up | 7 |
| | 4.5 Mixing Procedure | 7 |
| | 4.6 Premix Grouts | 7 |
| | 4.7 “Homemade” Grout | 8 |
| | 4.8 Cement | 8 |
| | 4.9 Water | 8 |
| | 4.10 Admixtures | 8 |
| | 4.11 Fly Ash | 8 |
| | 4.12 Sand | 9 |
| | PRE USE CHECK LIST | 10 |
| 5. | ILLUSTRATED PARTS CATALOGUE | 11 |
| | | |
| | | |

Intentionally Left Blank

1. SAFETY PROCEDURES

Recommended items to keep gunning safe:

- a. Hard hats.
- b. Safety goggles.
- c. Dust masks in confined spaces or unventilated areas.
- d. Good lighting.
- e. Whip check cables and chain safety couplings on air supply hoses.
- f. Rubber gloves to protect workmen with skins sensitive to cement burns (also use barrier cream).
- g. Sturdy and safe lifting devices, platforms and scaffolding for those many gunning operations that are performed off the ground. All platforms should be equipped with safety rails.
- h. A qualified electrician must do all electrical connections.
- i. Do not remove the screen/sieve supplied on the hopper whilst the machine is in operation.
- j. Do not carry out any maintenance whilst the air or electrical connections are connected to the machine.
- k. Do not poke or prod any instrument of any sort into the hopper whilst the machine is in operation.
- l. Use safety straps on all grout hose connections.
- m. Keep arms, hands, fingers etc away from moving parts.
- n. Disconnect power/air before attempting to clean or repair equipment.

2. TECHNICAL SPECIFICATIONS

| ROCKCRETER C70A | |
|--|--------------------------------|
| Dimensions | |
| Length | 1700 mm |
| Width | 900 mm |
| Loading Height | 1200 mm |
| Weight | +320kg |
| Output | Up to 2m ³ /Hr |
| Aggregate size | Up to 8 mm |
| Conveying Distance | |
| Horizontally | Up to 60m – material dependant |
| Vertically | Up to 30m |
| Air requirements | |
| 4 – 6 bar @ 100 c.f.m. for nozzle | |
| Drive | |
| 7.5kW on pump | |
| 4kW on mixer | |
| Options | |
| Electric drive – 380V / 525V or 1000V Flameproof | |
| Hydraulic drive | |
| Variable speed | |

3. PRINCIPLES OF OPERATION

NOTE:

The principles of operation offered herein are intended as an aid to help the operator identify some of the factors that need to be taken into consideration when mixing and pumping cementitious grouts. Because wide varieties of materials are available for many different applications, it is important the operator becomes familiar with the specific characteristics of the material he intends using.

Materials

1. Among the commercially manufactured materials available in today's market are materials for structural repairs, floor toppings, high strength non-shrink grouts, special linings and other specialty materials.
2. Each of these materials has unique characteristics, which must be well understood to insure a successful application.

Flow

1. In general, most materials need to be a flowable or pourable consistency for successful pumping. This means that if the material can be poured out of a pail or bucket, it can likely be pumped.
2. The exception to this requirement is repair mortars, which tend to be mixed in a thicker consistency and require special pumping techniques.
3. Materials that contain aggregates pump best and perform best when the consistency is kept to the lower range of pourable, that is, not too wet.

Setting Time

1. Some materials contain accelerating admixtures to reduce the setting time. This is particularly true of repair mortars and other spray applied materials so that strength gain can be fairly rapid. It is important to keep moving when using these types of materials.
2. Once the material is mixed, it must be pumped immediately and kept in motion and subsequent batches must be mixed and pumped as rapidly as possible. Any delays in the application process could result in plugged hoses and equipment.
3. Temperature also has an effect upon these materials to the extent that exposure of the hose to the sun on a hot day will accelerate the set time even more, therefore this should be avoided. It may even be necessary in some cases to cool the material, the mix water, or even the hose itself.

Pumping Distance

1. Pumping distances should always be kept to a minimum, and hoses should run as straight as possible no matter what material is being used.
2. Sometimes circumstances require longer than usual hose lengths, when this occurs, every effort should be made to use every advantage possible to insure a successful application. Some materials simply cannot be pumped for long distances, so it's best to know the proposed material characteristics before attempting a production procedure.

General Procedures

1. Before attempting to mix and pump production materials, it is important to rinse the mixer and charge the pump hopper with sufficient water to thoroughly flush the pump and all grout lines. This is to purge the grouting system of any residual materials or scale that may exist.
2. Once that is completed, remove the grout hose from the pump and drain out all water by elevating one end, or by progressively elevating the entire hose, at one end and proceeding to the other.
3. Mix slurry composed of Portland cement in approximate proportions of 25 litres of water to $\frac{1}{2}$ a bag of cement, and pump this through the grouting system. This is to remove any residual water from the hose, lubricating it for the production material to follow. Now the production grout may be mixed and pumped immediately behind the slurry mix.
4. The slurry mix may be retrieved in a bucket.

NOTE:

DO NOT attempt to pump production material through a dry hose. Occasionally, no matter how conscientious an operator may be, a hose will get plugged. Once this happens, the only sure way to remove the plug is to empty it of material. Beating on it with a hammer or running over it with a vehicle will not usually be successful. A prudent operator will be prepared for such eventuality.

ROC15007

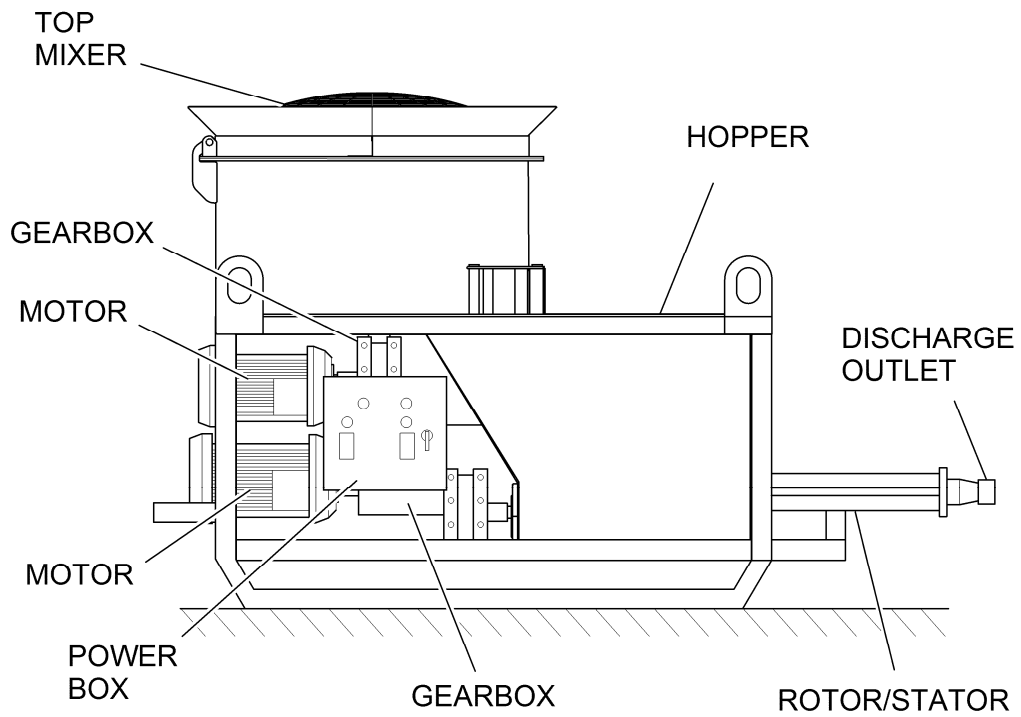

RE ROCKCRETER C70A

Figure 1

4. OPERATING PROCEDURES

Set- Up

1. In general, the most important factors in setting up are proximity to the work and access to materials and water supply, consideration should be given to the disposal of waste materials and wash-out residue.
2. It is always best to keep grout lines as short as possible to reduce pumping distances. This is particularly important when pumping hard-to-pump materials, such as sanded grouts and pre-blended materials.
3. The source of solid materials (cement, fly ash, sand, etc.) should be readily accessible and adequate supply water should be available for mixing and clean up.
4. When planning a project for high production rates, remember that the greatest consumption of time is when charging the mixers. A proper set-up can reduce this to a minimum.

Start-Up

1. After set up, visually inspect that there are no foreign objects or old set up materials in either the pump or the mixer, then make all necessary connections.
2. With operating levers, valves, or handles in “NEUTRAL” or “OFF” position and the primary power source turned OFF, fill the pump hopper with clear water.
3. Turn on the primary power source and observe that conditions are normal and machine is ready to run.
4. Check the mixer for proper operation by running the mixer and pump in the right direction.
5. Next, start the delivery pump to discharge the water that was previously introduced into the pump hopper. This ideal opportunity to check the grouting system to determine that all lines and hoses are clear and unobstructed. Pump condition may also be checked at this time by testing discharge pressure.
6. When it is determined that all systems are normal, shut off the pump and drain the water from the pump and all lines.
7. NOTE Some pre-blended materials and some on-site mixes of sand and cement tend to separate and clog the hoses upon contact with residual water in the hose, so it is a good procedure to mix and pump the production material, to lubricate the pump and hoses.

Production

1. During the production phase of work, monitor pump and mixer performance continuously, being alert to any signs of abnormality.
2. Keep mixers free of material build-up; keep the outside of the machine clean.

Clean-Up

NOTE:

Never run pump without fluid, as it will cause severe damage.

1. After disposing of excess production material, carefully wash out mixer paddles, screen into the pump hopper, and pump the resulting washout material through the grout hoses to a suitable disposal site.
2. Continue this operation until only clear water is discharged.
3. It is advisable to drain all residual wash water from the pump and all hoses when washout is complete

Mixing Procedure

1. Load approximately 80% of the water or liquid anticipated for the size batch to be mixed and with the mixer running add the required amount of cement.
2. Allow sufficient time for the slurry to mix to a creamy consistency, before pumping or adding filler material (sands, fly ash, etc), slowly add sand if required, until the mix just begins to lose the cement colour. This should be the maximum amount of sand the mix can accommodate and it may be necessary to use slightly less sand for subsequent batches.
3. The water may be adjusted for the relative wetness or dryness of sand to produce a grout that is just pourable.
4. Never switch the mixer off during mixing batches. This will cause excessive load and will damage the motor and gearbox.

Premix Grouts

1. Many building material suppliers manufacture pre-blended cement based grouts, of which are pumpable and some are not pumpable.
 2. Before attempting to pump a pre-blended grout material, determine whether the material conforms to the criteria described above. It is also necessary to determine whether the material has a short working time before set because there may be insufficient working time to pump.
 3. Before pumping any pre-blended cement-based grout mix, it is good practice to first coat the pump and lines with cement slurry mix as previously described, prior to pumping the grout mix.
-

“Homemade” Grout

1. Sometimes commercially prepared grouts are not readily available, and in these cases, it may be necessary to formulate and produce the material on site. This can be done quite successfully, but certain basic principles must be observed.
2. The resultant material should exhibit the following characteristics:
 - a. A stable suspension of solids that does not separate while at rest.
 - b. Colour must be predominantly that of the cement used.
 - c. Fluid enough to pour from a container, but not too wet. (Thick batter consistency)

Cement

1. There are several types of Portland cements manufactured to satisfy a variety of specific requirements, such a high early strength sulfate resistance and other needs.
2. The most common of these is Type I Portland, and is that which is most frequently used in the production of cementitious grout.

Water

1. In most instances, the water to be used for the production of grout should be clean and free of sulfates or other dissolved chemicals. If available, potable water is ideal.
2. Since the water to cement ratio is the important factor in the quality of the material in its final state, the water content should be kept to the minimum that will produce material with the characteristics listed above.

Admixtures

1. Admixtures are available to modify and enhance the grout mixture. These include plasticizers, water reducing agents, expansive agents, Anti-washout ingredients and others.
2. If used at all, they should be used only with a full understanding of their effects, and only according to the manufacturers’ recommendations.

Fly Ash

1. In some parts of the country, fly ash (a byproduct of coal burning power stations) is available. This material has often been used to enhance the properties of cementitious grouts or reduce them cement fraction in some cases.
2. Use of this material should be used with **CAUTION**, since ash from some sources has been observed to cause **FLASH SET** in grout mixes.

-
3. If the use of this product is anticipated, trial mixes should be made to prove their applicability.

Sand

1. If the use of sand is anticipated, several factors must be considered such as the shape, size and gradation of the sand to be used.
2. In general, the sand should be clean, well-graded and of rounded, natural shape. Regular particles such as manufactured sands should be avoided. Larger amounts of well graded and rounded, natural shape. Angular such as manufactured sands should be avoided. Larger amounts of well-graded and round shaped sand particles may be used in the mix rather than sand which is poorly graded or has a significant number of flat, sharp or angular particles.
3. Concrete sand is usually not pumpable but masonry and plaster sands usually are pumpable

ROCKCRETER C70A – PRE USE CHECK LIST

WARNING: REPORT DAMAGE, DEFECTS OR FAULTY OPERATION IMMEDIATELY. DO NOT OPERATE ROCKCRETE PUMP UNTIL CORRECTED

| | |
|--|-----------------------------|
| | Checked and in order |
| | Checked and found defective |

SAFETY PRECAUTIONS

1. Isolate all air & electric's during inspection and maintenance.
2. Keep hands away from moving parts.
3. Wear all necessary safety gear.

BEFORE STARTING THE ROCKCRETER C70A

1. Check that air and water pressure is sufficient.
2. Check all air, electrical & water connections are in safe working order.
3. Check rotor and stator, if worn, replace. Apply grease before reassembling.
4. Check discharge, clean & replace if worn
5. Check hoses for any material or blockages before turning on the machine.
6. Check and make sure the sieve is in place and secure.
7. Check nozzle tip for any blockages, if blocked clean. Check o-rings. Apply grease on o-rings.
8. Check auger for wear.
9. Check clamps & gaskets are in place and secure to all fittings.

AFTER STARTING THE ROCKCRETER C70A

10. Check rotation of auger – anti clockwise
11. Check smooth operation of ROCKCRETER C70

NOTE: ALWAYS KEEP ENOUGH WATER ON SITE OF CLEANING

| CHECK | GO | NO GO |
|-------|----|-------|
| 1 | | |
| 2 | | |
| 3 | | |
| 4 | | |
| 5 | | |
| 6 | | |
| 7 | | |
| 8 | | |
| 9 | | |
| 10 | | |
| 11 | | |

Checked by: _____

Date: _____

Time: _____

Section: _____

Comments: _____

ROCKCRETER C70A

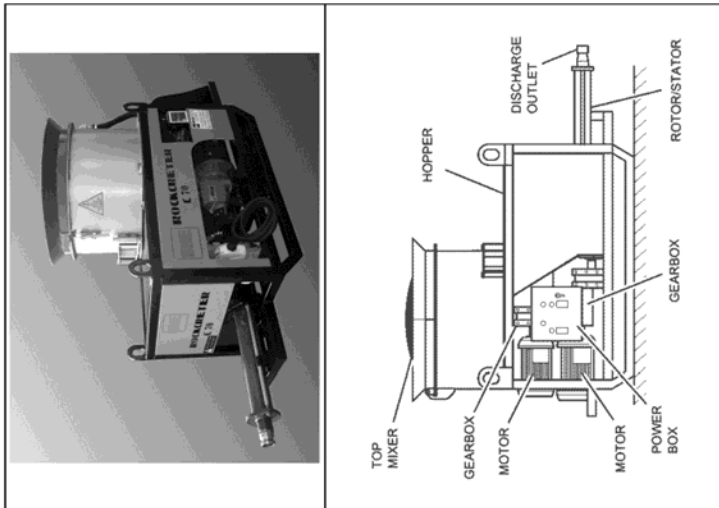

1. BODY ASSEMBLY

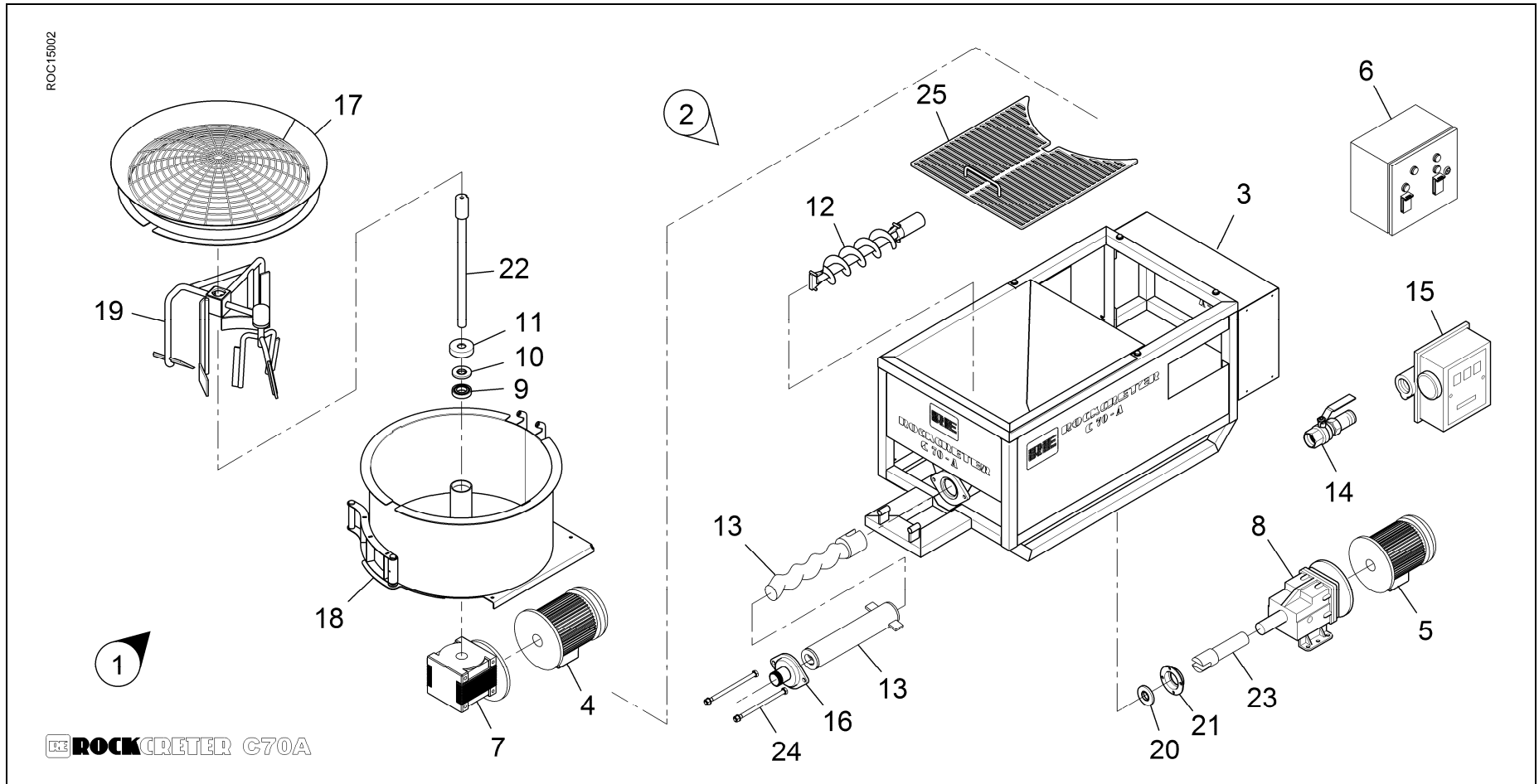

1. BODY ASSEMBLY

| ITEM NO | DESCRIPTION | PART NO | QTY | COMMENTS |
|---------|-----------------------------------|------------|-----|----------|
| 1 | C70 MIXER COMPLETE | KGPF002 | 1 | |
| 2 | C70 PUMP ASSEMBLY | ARC70E5 | 1 | |
| 3 | C70 HOPPER AND FRAME | KGPF013 | 1 | |
| 4 | ELECTRIC MOTOR 525V – 4 kW | EA028 | 1 | |
| 5 | ELECTRIC MOTOR 525V – 7.5 kW | EA028C | 1 | |
| 6 | BOX CONTROL DUAL – 525V – 7.5kW | EA037A | 1 | |
| 7 | C70 GEARBOX PUMP DRIVE | KGPF202 | 1 | |
| 8 | C70 INLINE GEARBOX | KGPF203 | 1 | |
| 9 | C70 MIXER TOP BEARING | KGPF014 | 1 | |
| 10 | C70 MIXER SHAFT SEAL | KGPF014-B | 1 | |
| 11 | C70 VASCONITE COVER | KGPF014-A | 1 | |
| 12 | AUGER C70A | KGPF003A | 1 | |
| 13 | MRT ROTOR / STATOR SET WITH CLAMP | KGPF005A-1 | 1 | |
| 14 | VALVE WATER 1" | PV05 | 1 | |
| 15 | FLOW METER | KGPF009 | 1 | |
| 16 | DISCHARGE OUTLET 50mm | KGPF006A | 1 | |
| 17 | SIEVE MIXER | KGPF050 | 1 | |
| 18 | HOPPER MIXER | KGPF051 | 1 | |
| 19 | MIXER ARM ASSEMBLY | KGPF052 | 1 | |
| 20 | C70A SEAL | KGPF001-D | 2 | |
| | | | | |

2. HOSE ASSEMBLY

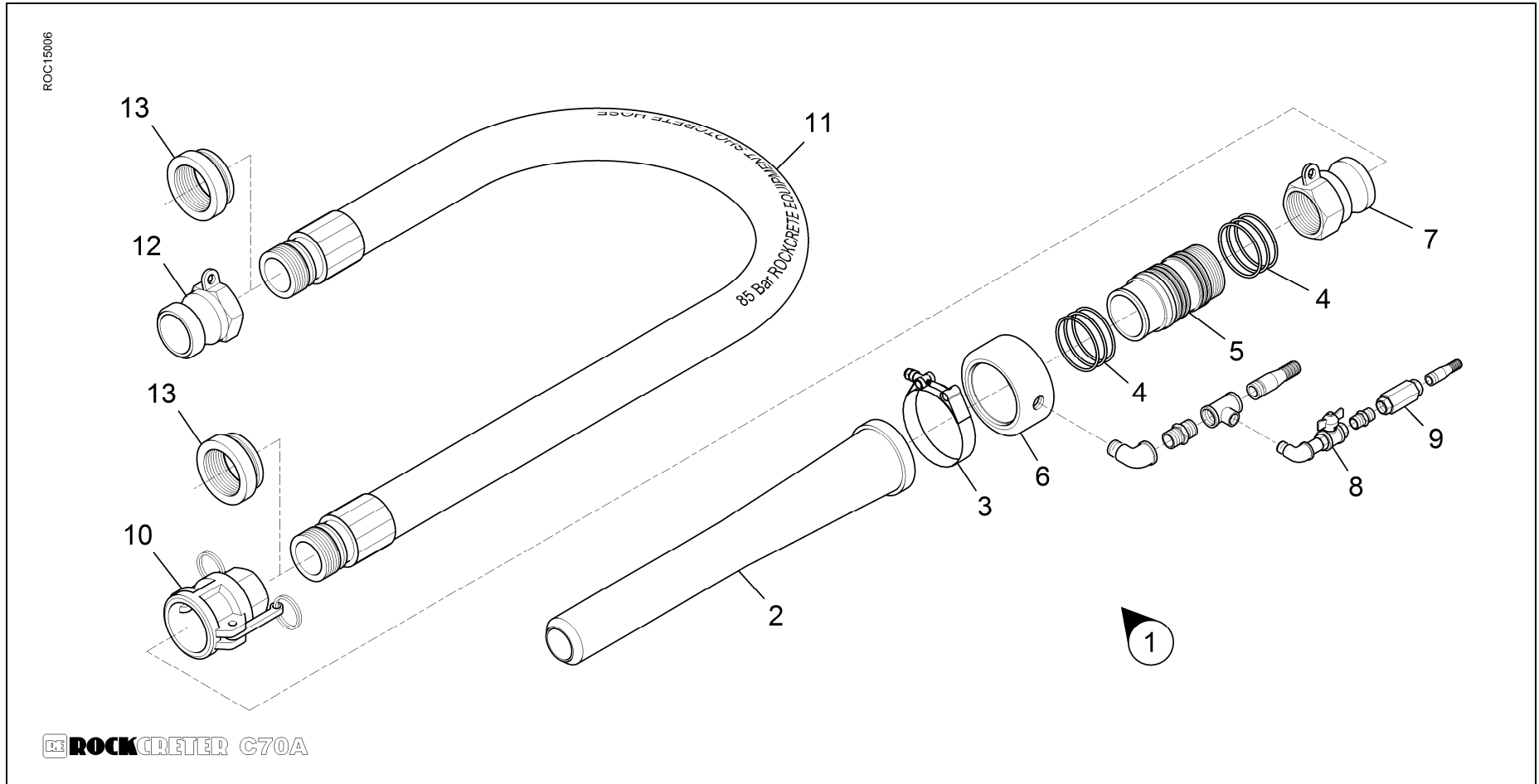

2. HOSE ASSEMBLY

| ITEM NO | DESCRIPTION | PART NO | QTY | COMMENTS |
|---------|---|---------|-----|----------|
| 1 | WETCRETE NOZZLE ASSEMBLY COMPLETE WITH FITTINGS | W001A | 1 | |
| 2 | WETCRETE NOZZLE TIP | W001D | 1 | |
| 3 | CLAMP B76 | E033E | 1 | |
| 4 | O-RING 74mm | W002 | 6 | |
| 5 | INJECTOR HOUSING | W001C-1 | 1 | |
| 6 | OUTER HOUSING | W001C-2 | 1 | |
| 7 | AS200 CAMLOCK | W006G | 1 | |
| 8 | NOZZLEBODY TAP | PV18 | 1 | |
| 9 | NON RETURN VALVE 1/2" | PV19 | 1 | |
| 10 | DS200 CAMLOCK | W006F | 1 | |
| 11 | 85 BAR SHOTCRETE HOSE WITH FITTINGS | W001 | 1 | |
| 12 | 2" A CAMLOCK S/STEEL | W006G | 1 | |
| 13 | 3" BSP COLLAR | W001S | 2 | |
| | | | | |
| | | | | |
| | | | | |
| | | | | |
| | | | | |
| | | | | |
| | | | | |

3. PLASTER HOSE ASSEMBLY

