



# ROCKCRETE

## EQUIPMENT (PTY) LTD

Company Reg. No: 1947/024677/07

### OPERATORS MANUAL FOR ROCKCRETER ANTLIA



**SOUTH AFRICAN SHOTCRETE TECHNOLOGY**  
*Designed to perform, the power to succeed!*

P. O. Box 18924 Sunward Park 1470 • 361 Crocker Road, Wadeville, Germiston, South Africa  
Co. Reg. no: 1947/24677/07

**TEL: (+2711) 865 3019 FAX: (+2711) 865 1346**  
**e-mail: [information@rockcrete.co.za](mailto:information@rockcrete.co.za)**  
**[www.rockcrete.co.za](http://www.rockcrete.co.za)**

As part of our policy of constant product development and improvement information and specifications contained in this document are liable to change.

**OPERATORS MANUAL  
FOR  
ROCKCRETER ANTLIA**



Intentionally Left Blank

---

## CONTENTS LIST

Figure	Description	Page No
1.	SAFETY PROCEDURES	1
2.	TECHNICAL SPECIFICATIONS	2
3.	PRINCIPLES OF OPERATION	2
	3.1 Materials	3
	3.2 Flow	3
	3.3 Setting Time	3
	3.4 Pumping Distance	3
	3.5 General Procedures	4
4.	OPERATION AND SAFETY	6
	4.1 Introduction	6
	4.2 Safety before Operation	6
	4.3 Safety during Operation	7
	4.4 Set-Up	7
	4.5 Operating the Pump	7
	4.4 Cleaning and Storage	8
	4.4 Mixing Procedure	8
	4.4 Premix Grouts	9
5.	MAINTENANCE	9
	5.1 Inspection	9
	5.2 Regular Inspection before, during and after usage	9
	5.3 Running Maintenance	10
	5.4 Resetting of Wear Ring/Wear Plate clearance	10
	5.5 Changing concrete Piston Cups	11

**OPERATORS MANUAL  
FOR  
ROCKCRETER ANTLIA**



---

	5.6 Changing S-Tube Shaft Seals and/or bushes	12
	5.7 Replacing Wear Ring and Wear Plate	13
6.	ILLUSTRATED PARTS CATALOGUE	15
7.	APPENDIX	
	7.1 Hydraulic Diagram	31

---

## **1. SAFETY PROCEDURES**

### **Recommended items to keep filling safe:**

- a. Hard hats.
- b. Safety goggles.
- c. Dust masks in confined spaces or unventilated areas.
- d. Good lighting.
- e. Whip check cables and chain safety couplings on air supply hoses.
- f. Rubber gloves to protect workmen with skins sensitive to cement burns (also use barrier cream).
- g. Sturdy and safe lifting devices, platforms and scaffolding for those many gunning operations that are performed off the ground. All platforms should be equipped with safety rails.
- h. A qualified electrician must do all electrical connections.
- i. Do not remove the screen/sieve supplied on the hopper whilst the machine is in operation.
- j. Do not carry out any maintenance whilst the air or electrical connections are connected to the machine.
- k. Do not poke or prod any instrument of any sort into the hopper whilst the machine is in operation.
- l. Use safety straps on all grout hose connections.
- m. Keep arms, hands, fingers etc away from moving parts.
- n. Disconnect power/air before attempting to clean or repair equipment.
- o. Examine and make the area safe according to mine standards from where the pump is situated to the area where the void filling is to be done.

## 2. TECHNICAL SPECIFICATIONS

<b>ROCKCRETER VOID FILL PUMP</b>	
<b>Dimensions</b>	
Length	2100 mm
Width	800 mm
Total Height	1450 mm
Loading Height	940 mm
Dry Weight	+540kg
Output	Up to 6m <sup>3</sup> /Hr
Aggregate size	Up to 13mm
Hydraulic Pressure	150 bar
Delivery Pressure	70 bar
<b>Conveying Distance</b>	
Horizontally	Up to 150m – material dependant
Vertically	Up to 70m
<b>Drive</b>	
11kW on pump / direct drive	
<b>Options</b>	
Electric drive – 380V / 525V or 1000V flameproof	
Hydraulic drive	
Variable speed	
Dosing capacity up to 120 l/hour	

---

### 3. PRINCIPLES OF OPERATION

**NOTE:**

The principles of operation offered herein are intended as an aid to help the operator identify some of the factors that need to be taken into consideration when mixing and pumping cementitious grouts. Because wide varieties of materials are available for many different applications, it is important the operator becomes familiar with the specific characteristics of the material he intends using.

**Materials**

1. Among the commercially manufactured materials available in today's market are materials for structural repairs, floor toppings, high strength non-shrink grouts, special linings and other specialty materials.
2. Each of these materials has unique characteristics, which must be well understood to insure a successful application.

**Flow**

1. In general, most materials need to be a flowable or pourable consistency for successful pumping. This means that if the material can be poured out of a pail or bucket, it can likely be pumped.
2. The exception to this requirement is repair mortars, which tend to be mixed in a thicker consistency and require special pumping techniques.
3. Materials that contain aggregates pump best and perform best when the consistency is kept to the lower range of pourable, that is, not too wet.

**Setting Time**

1. Some materials contain accelerating admixtures to reduce the setting time. This is particularly true of repair mortars and other spray applied materials so that strength gain can be fairly rapid. It is important to keep moving when using these types of materials.
2. Once the material is mixed, it must be pumped immediately and kept in motion and subsequent batches must be mixed and pumped as rapidly as possible. Any delays in the application process could result in plugged hoses and equipment.
3. Temperature also has an effect upon these materials to the extent that exposure of the hose to the sun on a hot day will accelerate the set time even more, therefore this should be avoided. It may even be necessary

---

in some cases to cool the material, the mix water, or even the hose itself.

### **Pumping Distance**

1. Pumping distances should always be kept to a minimum, and hoses should run as straight as possible no matter what material is being used.
2. Sometimes circumstances require longer than usual hose lengths, when this occurs, every effort should be made to use every advantage possible to insure a successful application. Some materials simply cannot be pumped for long distances, so it's best to know the proposed material characteristics before attempting a production procedure.

### **General Procedures**

1. Before attempting to mix and pump production materials, it is important to charge the pump hopper with sufficient water to thoroughly flush the pump and all grout lines. This is to purge the grouting system of any residual materials or scale that may exist.
2. Once that is completed, remove the grout hose from the pump and drain out all water by elevating one end, or by progressively elevating the entire hose, at one end and proceeding to the other.

### **NOTE:**

**DO NOT attempt to pump production material through a dry hose. Occasionally, no matter how conscientious an operator may be, a hose will get plugged. Once this happens, the only sure way to remove the plug is to empty it of material. Beating on it with a hammer or running over it with a vehicle will not usually be successful. A prudent operator will be prepared for such eventuality.**



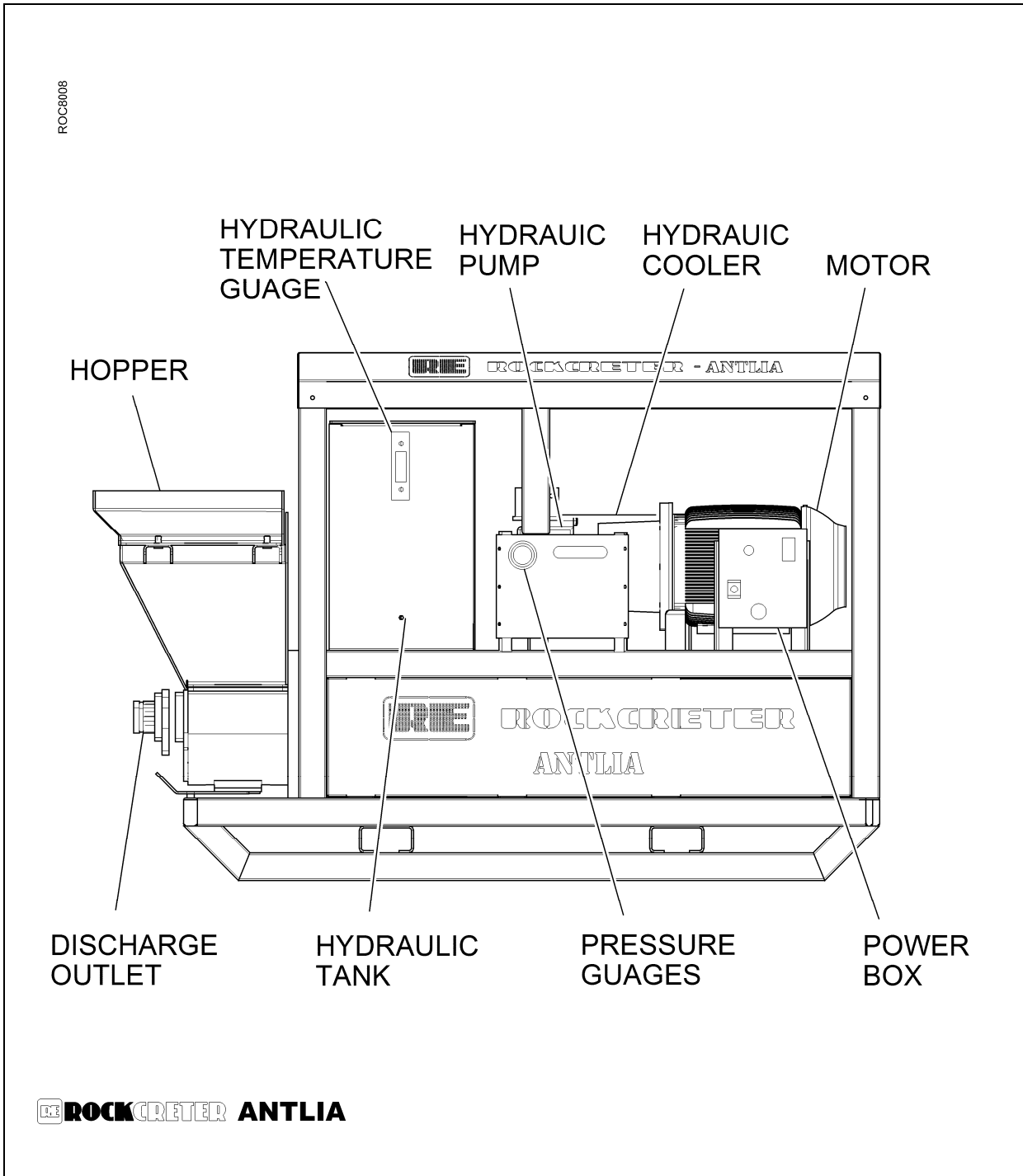

**Figure 1**

---

## **4. OPERATION AND SAFETY**

### **Introduction**

1. The Antlia Shotcrete Pump is a hydraulic pump for the spraying or pumping of wet concrete. The design is based on the proven dual cylinder and swing-tube design. Drive power is supplied from a 525 or 380v 3-Phase electrical motor driving one piston pump and one gear pump connected in tandem. The main pump supplies oil to the pumping and swing cylinders while the secondary pump drives the dosing pump. This unit is completely mechanical with no electronics.
2. The pump is designed for constant delivery of 6m<sup>3</sup>/h with adjustable dosing flow. Hydraulic pressure is pre-set at 150 bar for a concrete delivery pressure of 70 bar. This setting also protects the pump and other hydraulic components against over-pressure.

### **Safety before Operation**

1. As with all other hydraulic and rotating machinery, safety is extremely important when operating and maintaining the Antlia. The safety precautions provided in this manual must be used as a guide and not be seen as complete safety instructions.
2. Only personnel trained in the use of shotcreting pumps and systems must be allowed to operate the Antlia.
3. Always make sure the machine is clean and in good physical condition. This will reduce the possibility of injury or damage.
4. Before operating the machine check and make sure of the following:
  - a. Machine is placed on a suitable horizontal surface.
  - b. Necessary signs or arrangements are in place for the use of the machine.
  - c. All guards and covers are in place and secure
  - d. Hopper grid is closed and in good condition.
  - e. Hopper is clean and free of foreign objects.
  - f. Lubrication box is clean and half filled with hydraulic oil.
  - g. Lubrication box lid is closed.
  - h. Electrical panel is closed and free of damage.
  - i. All switches are secured and in good working condition.
  - j. Hydraulic pipes are secured and free of damage.
  - k. Pressure gauge is operational and undamaged.
  - l. Temperature and level gauge is operational and free of damage.

### **Safety during Operation**

1. Wear the required personal protective equipment.
2. Do not try to remove any foreign objects from the hopper through the grid
3. Keep clear of all moving parts
4. Never open the electrical panel while the machine is in operation.
5. Do not remove pipes or clamps under pressure.
6. Regularly check temperature and pressure to be within limits. Normal temperature during operation is between 30° C and 60° C.
7. Oil pressure should never read higher than 140 bar.
8. Only trained personnel should operate the machine.

### **Set- Up**

1. In general, the most important factors in setting up are proximity to the work and access to materials and water supply, consideration should be given to the disposal of waste materials and wash-out residue.
2. It is always best to keep grout lines as short as possible to reduce pumping distances. This is particularly important when pumping hard-to-pump materials, such as sanded grouts and pre-blended materials.
3. The source of solid materials (cement, fly ash, sand, etc.) should be readily accessible and adequate supply water should be available for mixing and clean up.

### **Operating the Pump**

1. Set the machine up on a suitable Horizontal surface.
  2. Follow all precautions and safety regulations.
  3. Make sure the hopper is clean.
  4. Close the hopper grid
  5. Make sure the lubrication box is clean
  6. Fill the lubrication box with oil or water to the center of the cylinder rod.
  7. Connect the concrete hoses to the outlet.
  8. Connect the dosing line from the dosing pump to the nozzle.  
Depending on the type of accelerator used might require bleeding of this line to ensure air evacuation and correct dosage before connection to the nozzle.
  9. Connect the dosing supply to the dosing pump inlet.
  10. Connect the air supply line to the nozzle.
  11. Switch off the main breaker and connect the machine to a suitable power supply.
-

- 
12. Switch on the main breaker. The LED on the phase sequence relay will only light up once the lines are connected in the correct order to ensure correct motor rotation. Incorrect motor rotation will damage the pump and hydraulic components.
  13. Enable the pump by turning the red Emergency Stop Button clockwise.
  14. Start the motor using the Start Button. The motor will run whilst the cylinders are stationary.
  15. Start the pump in Forward and make sure the machine runs smoothly.  
NOTE: The pump is equipped with self-bleeding cylinders. When the pump is switched on in the Forward or Reverse position, it might take a few seconds to correct itself by removing any trapped air or correcting cylinder positions.
  16. Check the oil and pressure rise to be below 40 bar with the pump in neutral.
  17. Add the required amount of an approved lubricator to the hopper to lubricate the concrete hoses.
  18. Follow the guidelines for applying shotcrete.
  19. Stop the pump using the Forward/Reverse switch.
  20. Switch off the motor with the red Emergency Stop Button.
  21. Blockages can be removed by running the pump in Reverse.

### **Cleaning and Storage**

1. Always clean the machine properly after every use while concrete is still wet.
2. Wash out the S-Tube and Concrete Cylinders through the Outlet with the machine running in reverse.
3. Remove all concrete from the hopper by washing it out through the bottom gate. Drain and clean the lubrication box and replace the plug and lid.
4. DO NOT put hands or any objects into the lubrication box while the machine is switched on.
5. Wash out the Dosing Pump with clean water by running it at low speed with the water supply connected to the suction port. Refill the hydraulic tank with the correct oil to the center of the level gauge.

### **Mixing Procedure**

1. Load approximately 80% of the water or liquid anticipated for the size batch to be mixed and with the mixer running add the required amount of cement.

2. Allow sufficient time for the slurry to mix to a creamy consistency, before pumping or adding filler material (sands, fly ash, etc), slowly add sand if required, until the mix just begins to lose the cement colour. This should be the maximum amount of sand the mix can accommodate and it may be necessary to use slightly less sand for subsequent batches.
3. The water may be adjusted for the relative wetness or dryness of sand to produce a grout that is just pourable.
4. Never switch the mixer off during mixing batches. This will cause excessive load and will damage the motor and gearbox.

### **Premix Grouts**

1. Many building material suppliers manufacture pre-blended cement based grouts, of which are pumpable and some are not pumpable.
2. Before attempting to pump a pre-blended grout material, determine whether the material conforms to the criteria described above. It is also necessary to determine whether the material has a short working time before set because there may be insufficient working time to pump.
3. Before pumping any pre-blended cement-based grout mix, it is good practice to first coat the pump and lines with cement slurry mix as previously described, prior to pumping the grout mix.

## **5. MAINTENANCE**

### **Inspection**

1. Regulator inspection and maintenance will ensure optimum performance and increase machine life expectancy. Regular inspection will reduce the risk of injury or plant and equipment damage. Worn and damaged parts should be replaced immediately with approved parts.

### **Regular Inspection before, during and after usage**

1. Hydraulic fluid leaks.
2. Swing Cylinder clevis, pin and securing pin.
3. Condition of hydraulic pipes and fittings.
4. Condition of all guards and covers.
5. Condition of electrical panel, switches, cables and wires.
6. Level of hydraulic oil in tank
7. Excessive movement of S-Tube indicating worn bushes and seals.
8. Concrete inside lubrication box indicating worn piston cups.
9. Drastically reduced output an indication of incorrect mix or possible pump or cylinder damage.

- 
10. Condition of seals.
  11. General condition of frame and structure.
  12. Proper closing of bottom gate.

### **Running Maintenance**

1. For replacement of parts always refer to Spares List.
2. Replacement of oil filter.
  - a. Greasing of the following points:
  - b. Change over cylinder pin.
  - c. S-Tube bushes front and rear.
  - d. Hopper grid hinges.
3. Draining off moisture/water from oil tank.
4. Refilling of oil tank
5. Retightening of any loose bolts or fittings.

### **Resetting of Wear Ring/Wear Plate clearance**

1. Once the Wear Plate or Wear Ring is worn to the point that the Wear ring is loose inside the S-Tube, the S-Tube must be adjusted to ensure correct sealing between the two faces.
2. Loosen Locking Cap Screw.
3. Loosen Outlet Nuts
4. Tighten S-Tube Shaft Nut until Wear Ring presses firmly against Wear plate. **DO NOT over-tighten.**
5. Replace and tighten Locking Cap Screw.
6. Adjust outlet gap by equally tightening Adjusting Nuts. The gap should be equally adjusted to between 0.5mm and 1mm.
7. Retighten Outlet Nuts.

### Changing concrete Piston Cups

1. When excess concrete is pushed out behind the concrete cylinders and into the lubrication box the concrete cylinder cups are worn through and need to be replaced.
  - a. Using the Operating Procedure, start the machine in neutral.
  - b. Switch the pump in reverse and push the one cylinder to the front.
  - c. Switch off the pump using the Emergency Stop.
  - d. Make sure the Bolt (1) head holding the Piston Cap is clean.
  - e. Redo steps a-d for second cylinder.
  - f. Switch off mains to machine.
  - g. Use metric 17mm socket and suitable extensions to loosen and remove the Bolt (1)(ST107), Spring Washer (2)(ST106) and Piston Cap (3)(ST105). Hold the Piston Cup Connector (4)(ST102) through the Lubrication Box with a 28mm flat spanner to prevent turning.
  - h. Remove all tools and push the cylinder forward in reverse.
  - i. Remove the Cup (5)(ST104) and Scraper (6)(ST103) and replace with new parts using suitable grease lubricant.
  - j. Replace Piston Cap (3) with Bolt (1) and Spring Washer (2). Add grease to bolt thread before inserting.
  - k. Repeat steps f-j for second cylinder.

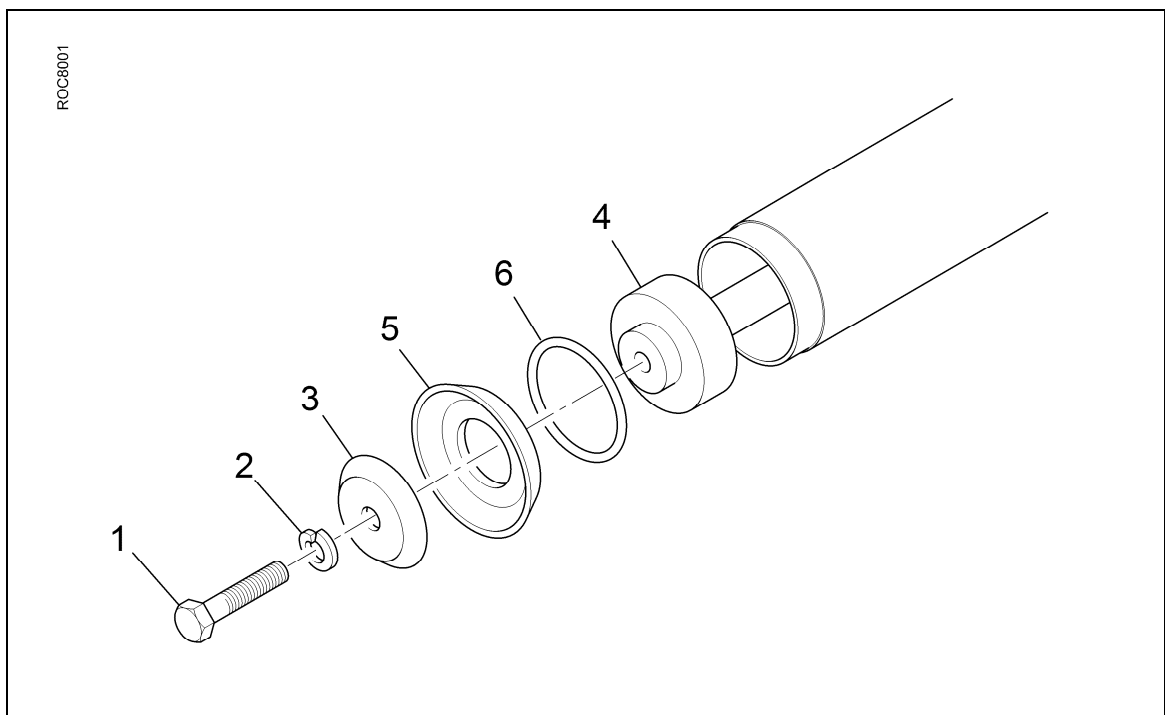

### **Changing S-Tube Shaft Seals and/or bushes**

- a. Remove Hopper from Feeder Box to allow access.
- b. Loosen nuts and remove Outlet Flange (ST207) and Outlet Bush Housing (ST202).
- c. Remove Internal Circlip (ST205) and replace Seals (2)(EA016) and/or Outlet Bush (ST204) if necessary. Make sure lubrication holes in bush are correctly aligned into housing. Use a suitable grease lubrication on seals and bushes.
- d. Remove S-Tube Locking Nut (12)(ST301).
- e. Split S-Tube (6)(ST201) and S-Tube Shaft (7)(ST308) inside Feeder box.
- f. Remove S-Tube (6)(ST201).
- g. Remove S-Tube Shaft (7)(ST 308).
- h. Remove Inlet Bush Housing Cover.
- i. Remove Shaft Seal (KGPFF001) and/or Inlet Bush (ST307) and replace.
- j. Replace Thrust Washers (ST306) adding grease.
- k. Reverse procedure to rebuild.
- l. Follow Wear Plate Gap Procedure to reset S-Tube.
- m. Grease all points.

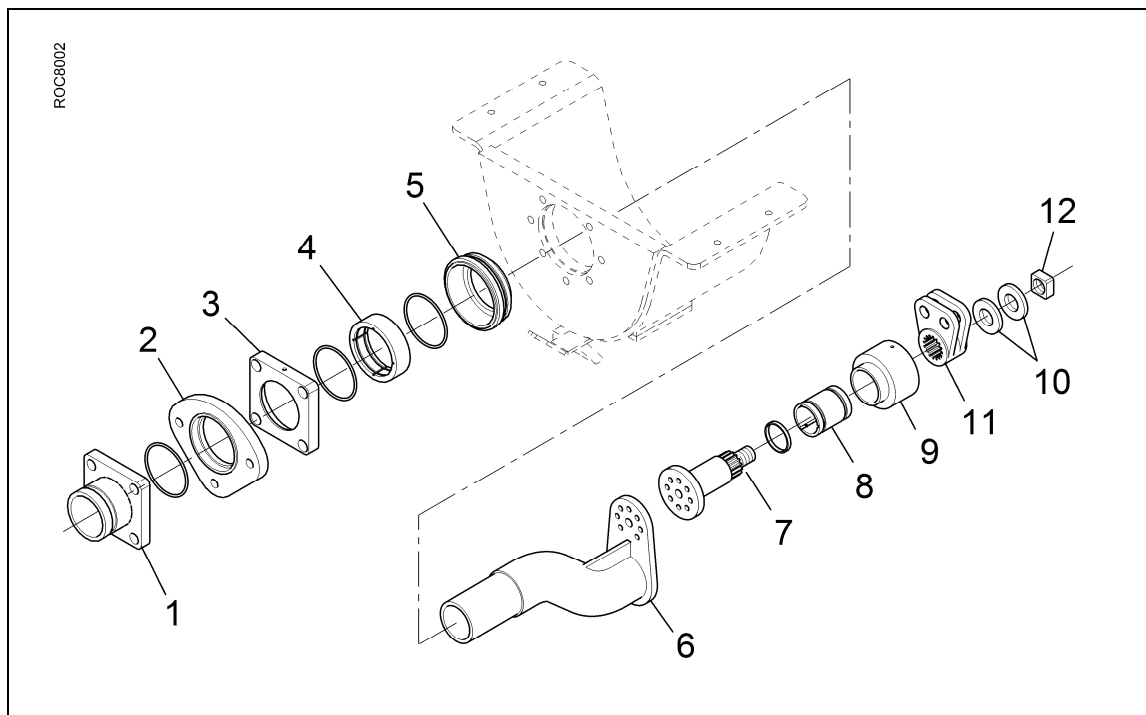



### Replacing Wear Ring and Wear Plate

1. Follow above procedure Steps a-h to loosen S-Tube. Do not split S-Tube.
2. Pull back S-Tube just enough to remove Wear Ring (2)(ST310) and Wear Ring O-Ring (3)(ST311).
3. Loosen Wear Plate Bolts.
4. Remove and replace Wear Plate (1) (ST309). Make sure the surface is clean to ensure proper sealing and alignment.
5. Replace Wear Ring and Wear Ring O-Ring.
6. Reverse procedure to re-assemble.
7. Grease all points.
8. Reset Wear Plate and Outlet gaps.

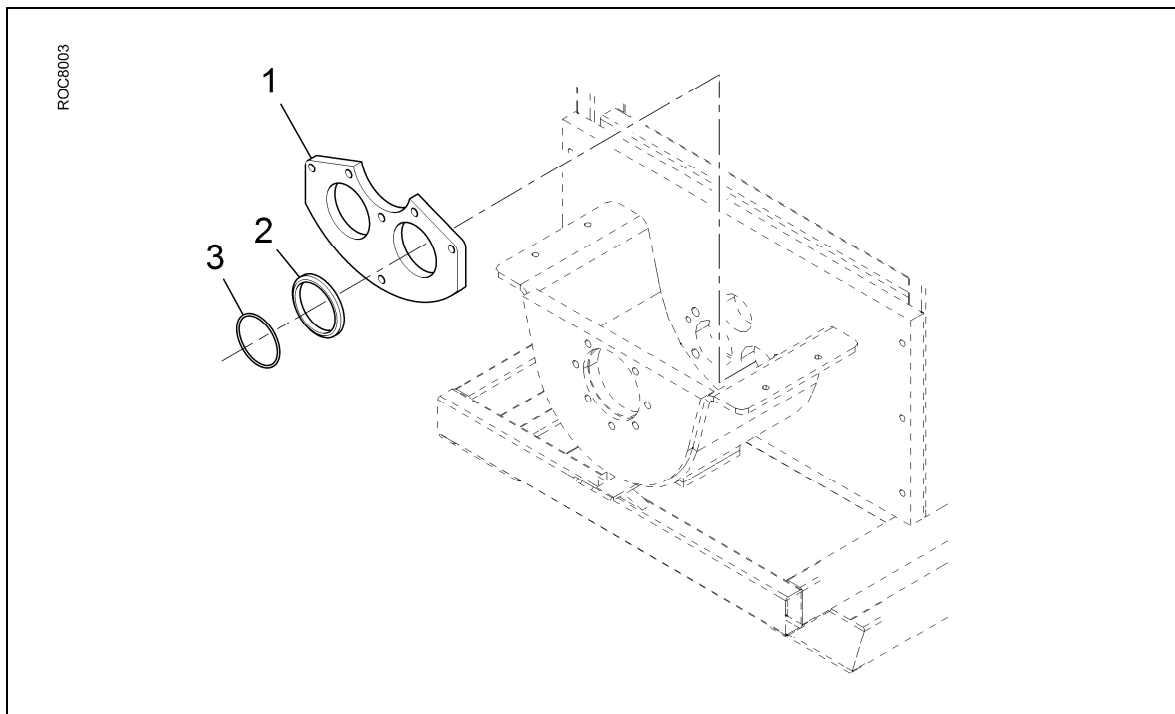

**ROCKCRETER ANTLIA – PRE USE CHECK LIST**

**WARNING: REPORT DAMAGE, DEFECTS  
OR FAULTY OPERATION IMMEDIATELY.  
DO NOT OPERATE ROCKCRETE PUMP UNTIL  
CORRECTED**

	Checked and in order
	Checked and found defective

**SAFETY PRECAUTIONS**

1. Isolate all air & electric's during inspection and maintenance.
2. Keep hands away from moving parts.
3. Wear all necessary safety gear.

**BEFORE STARTING THE ROCKCRETER ANTLIA**

1. Check machine is placed on a suitable horizontal surface.
2. Check signs or arrangements are in place for the use of the machine.
3. Check all guards and covers are in place and secure
4. Check hopper grid is closed and in good condition
5. Check hopper is clean and free of foreign objects.
6. Check lubrication box is clean and half filled with hydraulic oil.
7. Check lubrication box lid is closed.
8. Check electrical panel is closed and free of damage
9. Check all switches are secured and in good working condition.
10. Check hydraulic pipes are secured and free of damage.
11. Check pressure gauge is operational and undamaged.
12. Check temperature and level gauge is operational and free of damage.

**AFTER STARTING THE ROCKCRETER ANTLIA**

1. Check rotation of auger – anti clockwise
2. Check smooth operation of ROCKCRETER ANTLIA

**NOTE: ALWAYS KEEP ENOUGH WATER ON SITE FOR CLEANING**

CHECK	GO	NO GO
1		
2		
3		
4		
5		
6		
7		
8		
9		
10		
11		
12		

13		
14		

Checked by: \_\_\_\_\_

Date: \_\_\_\_\_

Time: \_\_\_\_\_

Section: \_\_\_\_\_

Comments: \_\_\_\_\_

ROCKCRETER ANTLIA

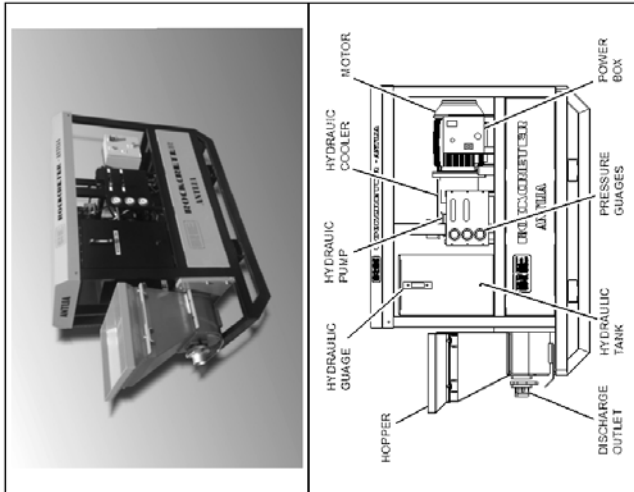



**1. BODY ASSEMBLY**

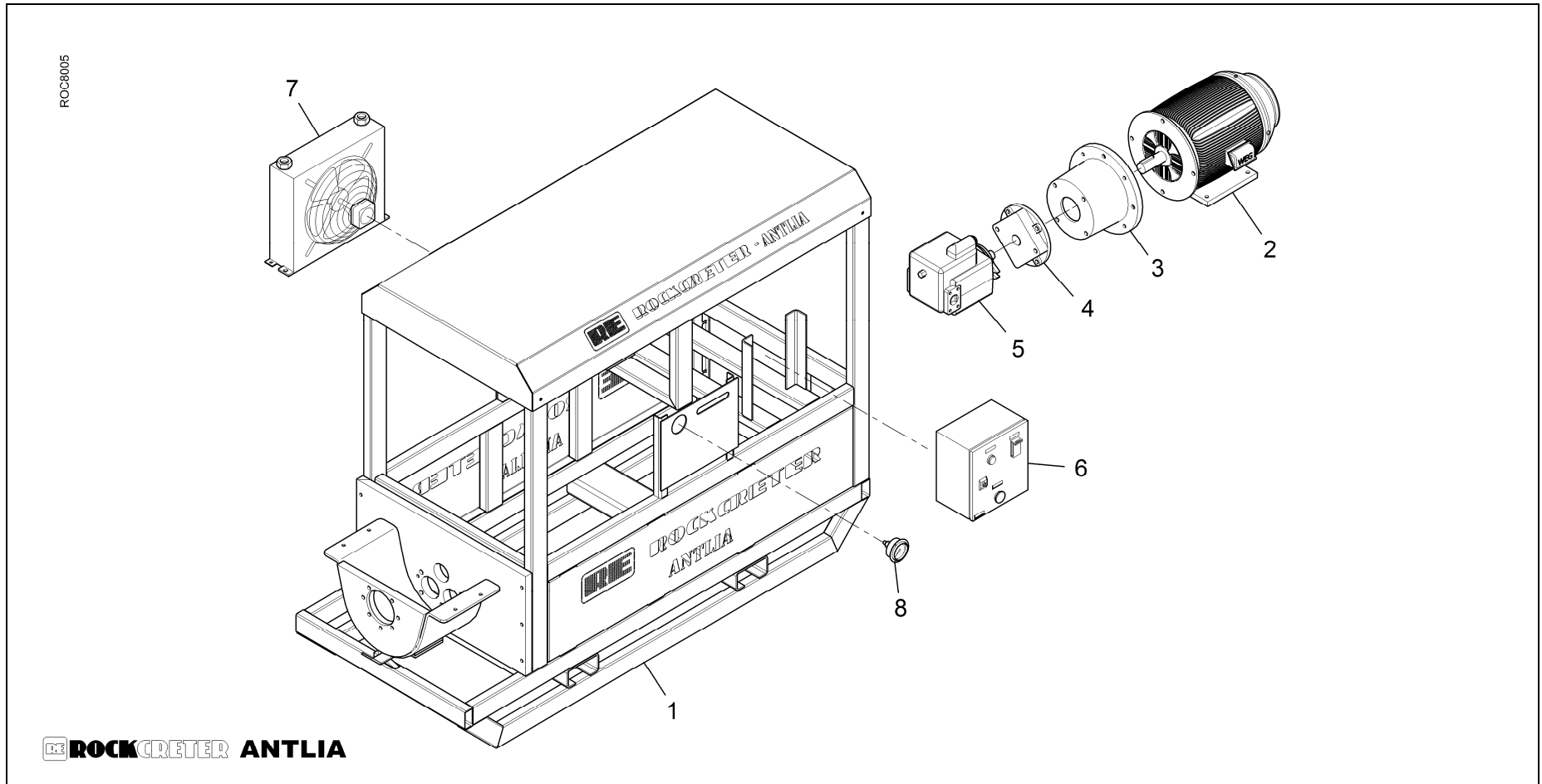



**2. HOPPER ASSEMBLY**

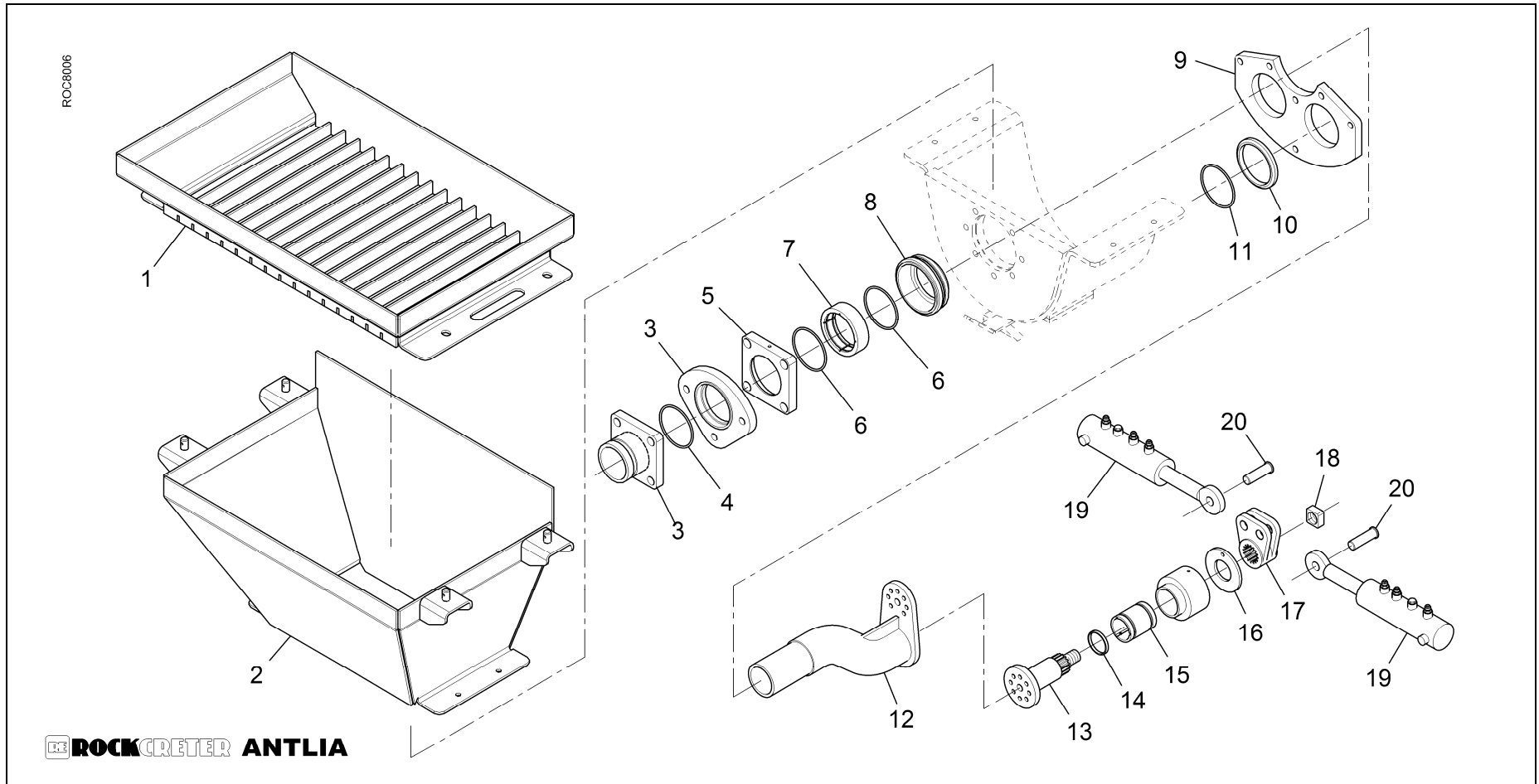

## 2. HOPPER ASSEMBLY

ITEM NO	DESCRIPTION	PART NO	QTY	COMMENTS
1	SEIVE	ST001A	1	
2	HOPPER	ST002	1	
3	S-TUBE DISCHARGE FLANGE	ST207	1	
4	SEAL	EA016	1	
5	GREASE NIPPLE FLANGE	ST202	1	
6	VESCONITE BUSH	ST204	1	
7	SEAL	ST203	2	
8	MACHINED VESCONITE HOUSING	ST205	1	
9	WEAR PLATE	ST309	1	
10	WEAR RING	ST310	2	
11	O-RING	ST311	2	
12	S-TUBE	ST201	1	
13	S-TUBE SHAFT	ST007	1	
14	SEAL	KGPF001B	1	
15	BRASS BUSH INLET	ST307	1	
16	SWIVEL ARM SPACER	ST302	1	
17	SWIVEL ARM	ST303	1	
18	S-TUBE LOCKING NUT	ST301	1	
19	CYLINDER	STY-050-A	2	
20	PIN	ST-050A	2	

**3. CYLINDER ASSEMBLY**

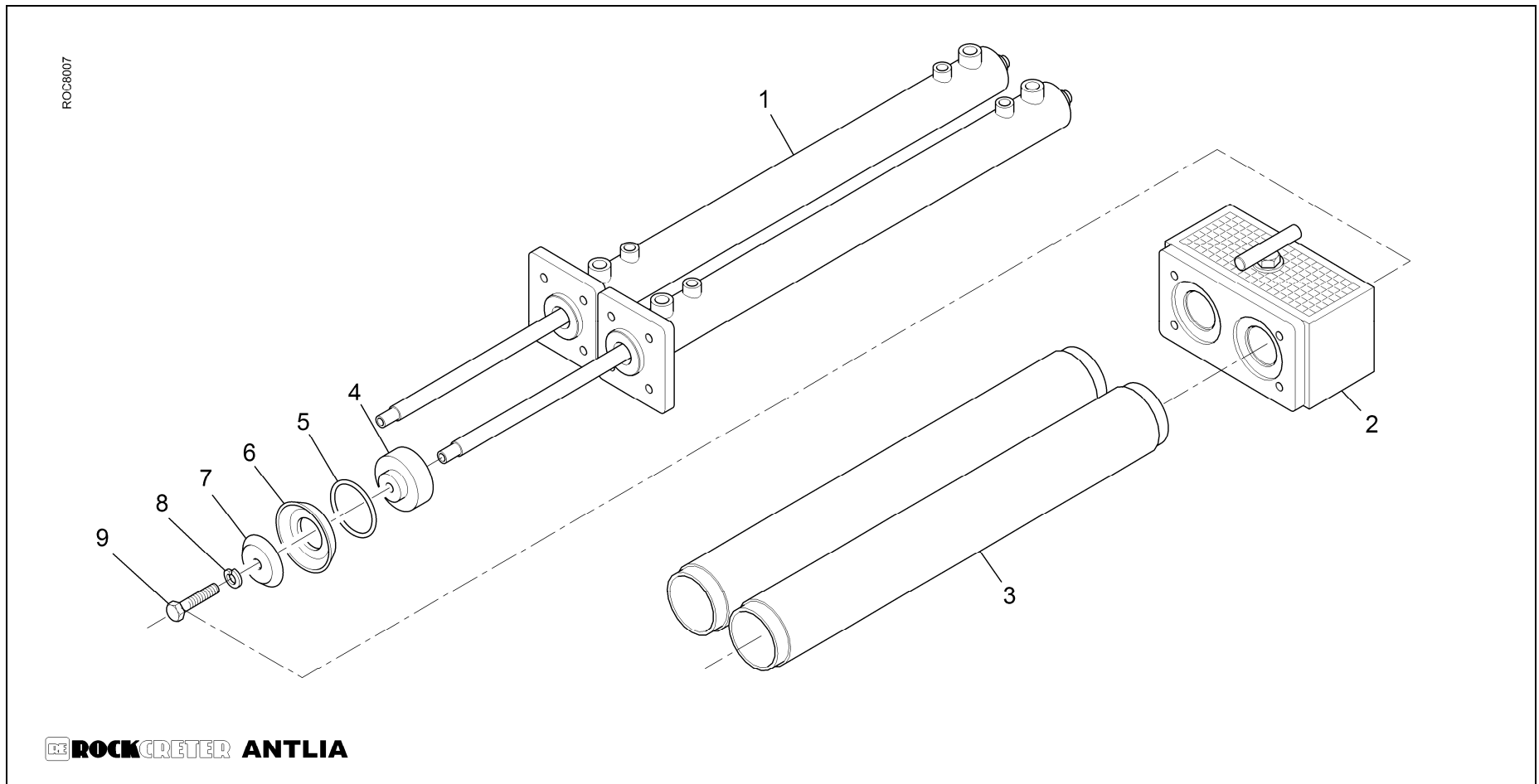



**3. CYLINDER ASSEMBLY**

ITEM NO	DESCRIPTION	PART NO	QTY	COMMENTS
1	CYLINDER	STY-050	2	
2	LUB BOX / WATER BOX	STY-050-B	2	
3	CONCRETE PUMPING TUBE	ST101	2	
4	PISTON CUP CONNECTOR	ST102	2	
5	SCRAPER	ST103	2	
6	PISTON CUP	ST104	2	
7	PISTON CUP / WASHER	ST105	2	
8	SPRING WASHER	ST106	2	
9	HEX BOLT M10 X 50	ST107	2	

**4. HYDRAULIC TANK**

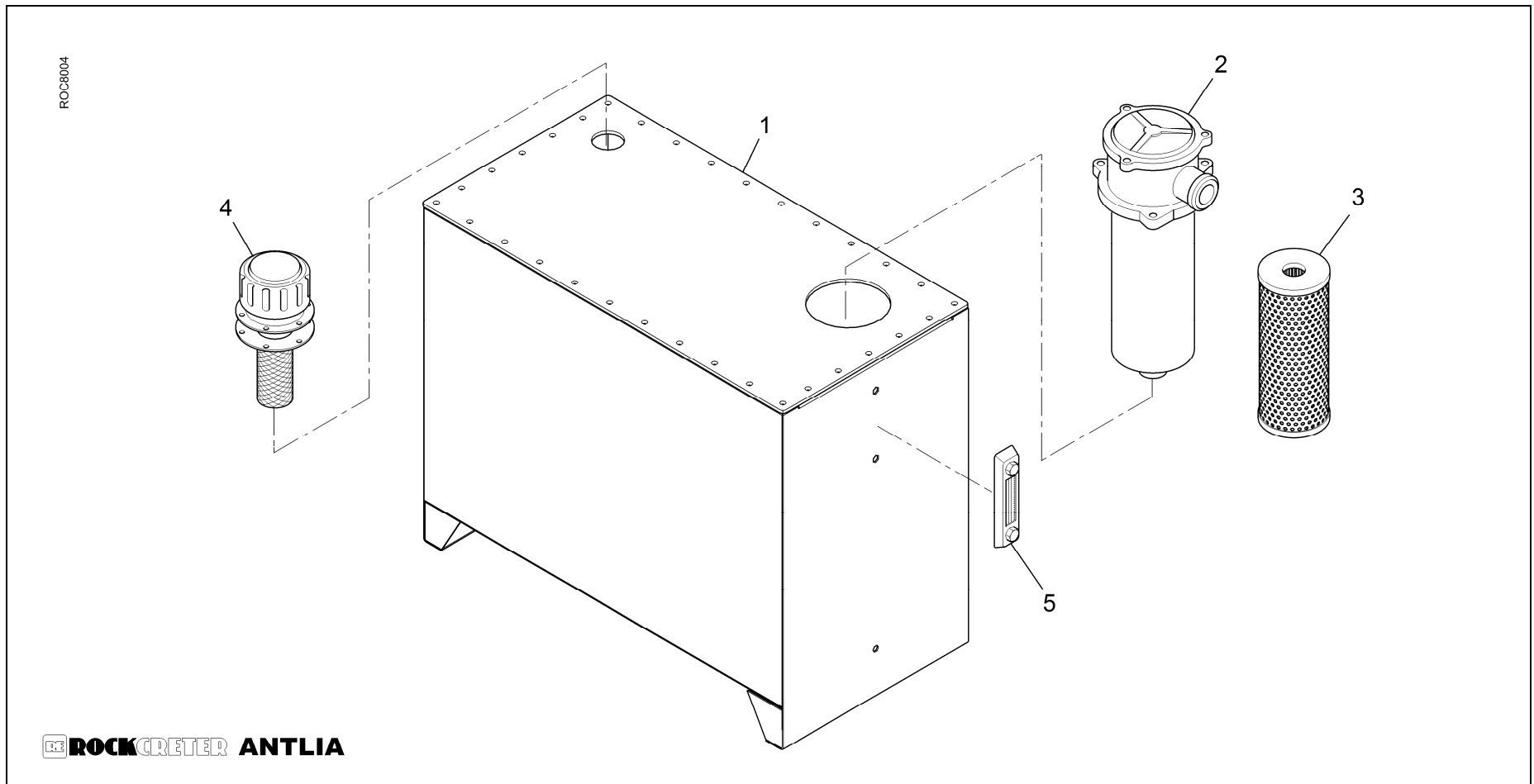



**5. HYDRAULIC HOSES**

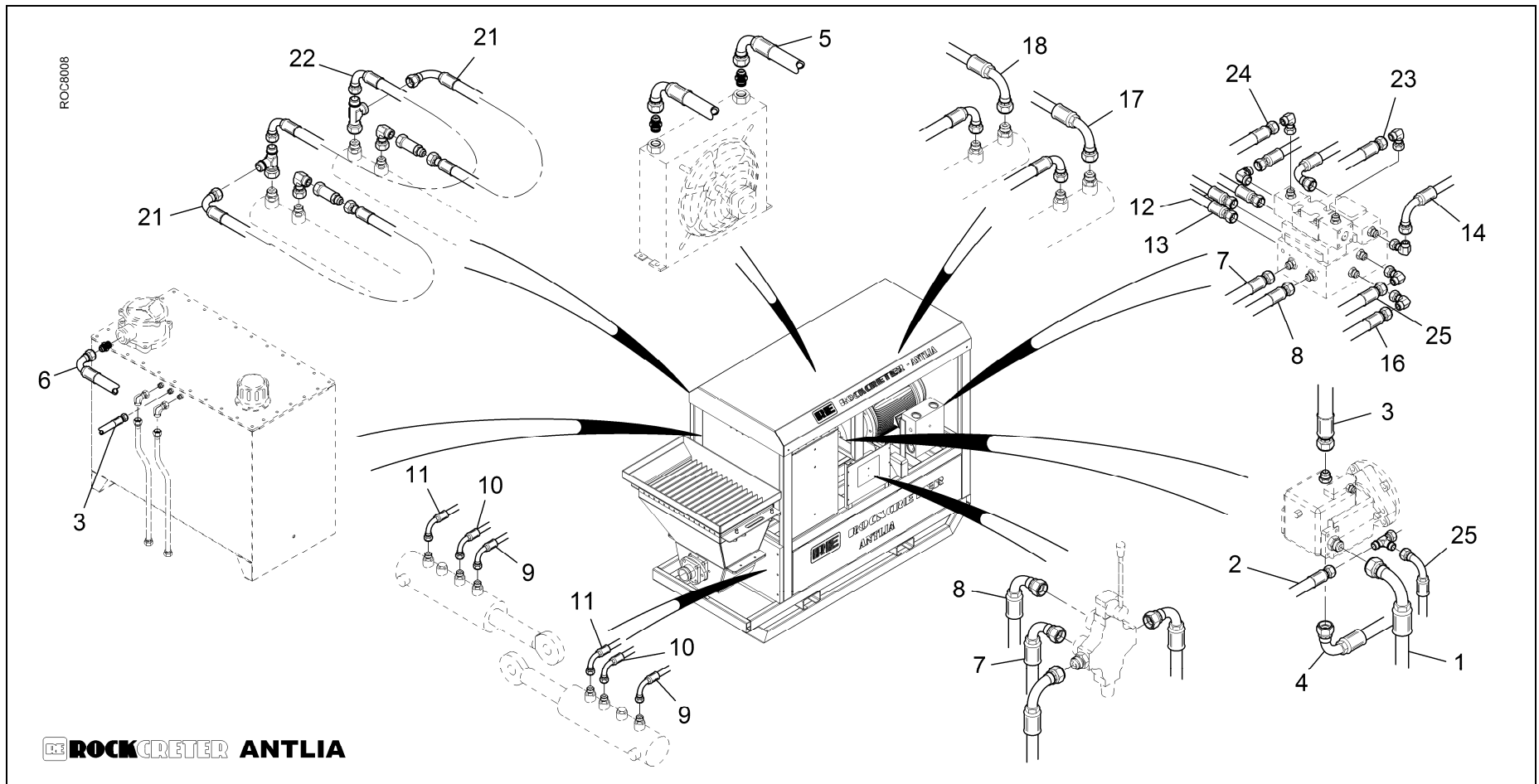

## 5. HYDRAULIC HOSES

ITEM NO	DESCRIPTION	PART NO	QTY	COMMENTS
1	P LINE 600 LONG 22L STR/90	STH001	1	2 WIRE
2	LOADSENSING 350 LONG 12L STR/90	STH002	1	2 WIRE
3	LEAKAGE LINE ON PUMP 450 LONG 12 L STR/STR	STH003	1	2 WIRE
4	SUCTION 550 LONG 35L 90/90@90°	STH004	1	1 WIRE
5	TANK TO COOLER 850 LONG 28L 90/90@90°	STH005	1	1 WIRE
6	COOLER TO TANK 500 LONG 28L 90/90@90°	STH006	1	1 WIRE
7	A PRESSURE LINE 800 LONG 22L STR/90	STH007	1	2 WIRE
8	B PRESSURE LINE 700 LONG 22L STR/90	STH008	1	2 WIRE
9	SMALL CYL A & B 600 LONG 12L 90/90@180°	STH009	2	2 WIRE
10	SMALL CYL PILOT A & B 600 LONG 12L 90/90@180°	STH010	2	2 WIRE
11	SMALL CYL TANK LINE A & B 500 LONG 12L 90/90@90°	STH011	2	2 WIRE
12	MANIFOLD TO CYL A 350 LONG 12L STR/STR	STH012	1	2 WIRE
13	MANIFOLD TO CYL B 350 LONG 12L STR/STR	STH013	1	2 WIRE
14	SMALL CYL A PILOT TO MANIFOLD 900 LONG 12L STR/90	STH014	1	2 WIRE
15	SMALL CYL B PILOT TO MANIFOLD 600 LONG 12L STR/90	STH015	1	2 WIRE
16	X & Y DRAIN LINE 1200 LONG 12L STR/STR	STH016	1	2 WIRE
				2 WIRE

**5. HYDRAULIC HOSES (CONTINUED)**

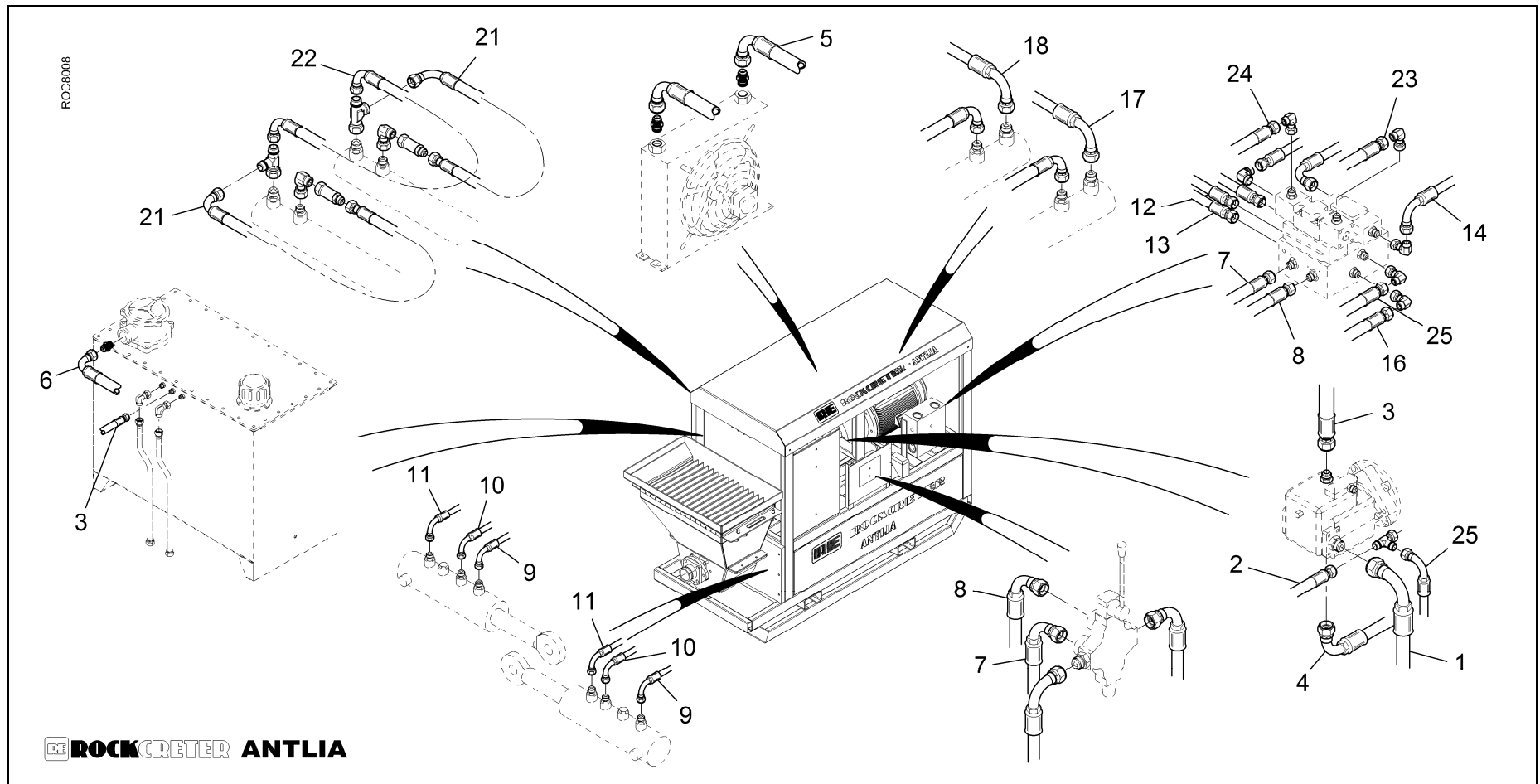

**5. HYDRAULIC HOSES (CONTINUED)**

ITEM NO	DESCRIPTION	PART NO	QTY	COMMENTS
17	A PUMP CYL TO MANIFOLD 750 LONG 18L 90/90@90°	STH017	1	2 WIRE
18	B PUMP CYL TO MANIFOLD 700 LONG 18L STR/90	STH018	1	2 WIRE
19	PILOT GAUGE HOSE 800 LONG ¼ - 10L MINIMESS HOSE	STH019	2	2 WIRE
20	PILOT GAUGE HOSE 400 LONG ¼ - 10L MINIMESS HOSE	STH020	1	2 WIRE
21	CYL A & B CHECK VALVE HOSE 500 LONG 12L STR/90	STH021	2	2 WIRE
22	A-B CYL COMBINE HOSE 500 LONG 18L 90/90	STH022	1	2 WIRE
23	PILOT HOSE 800 LONG 12L STR/STR	STH023	1	2 WIRE
24	PILOT HOSE 600 LONG 12L STR/90	STH024	1	2 WIRE
25	PILOT HOSE 1000 LONG 12L STR/STR	STH025	1	2 WIRE

**6. HOSE ASSEMBLY**

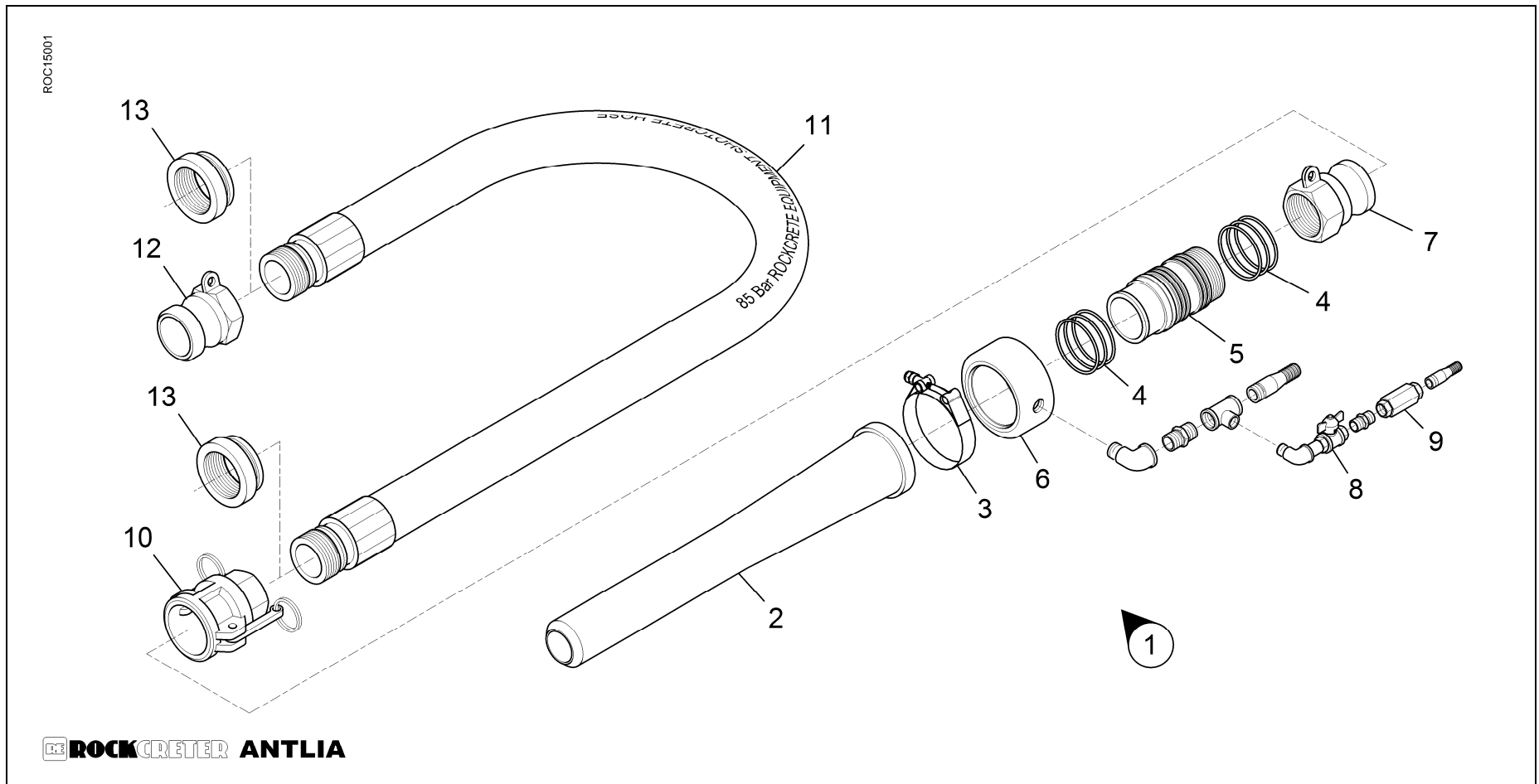



## 6. HOSE ASSEMBLY

ITEM NO	DESCRIPTION	PART NO	QTY	COMMENTS
1	WETCRETE NOZZLE ASSEMBLY COMPLETE WITH FITTINGS	W001A	1	
2	WETCRETE NOZZLE TIP	W001D	1	
3	CLAMP B76	E033E	1	
4	O-RING 74mm	W002	6	
5	INJECTOR HOUSING	W001C-1	1	
6	OUTER HOUSING	W001C-2	1	
7	AS200 CAMLOCK	W006G	1	
8	NOZZLEBODY TAP	PV18	1	
9	NON RETURN VALVE ½"	PV19	1	
10	DS200 CAMLOCK	W006F	1	
11	85 BAR SHOTCRETE HOSE WITH FITTINGS	W001	1	
12	2" A CAMLOCK S/STEEL	W006G	1	
13	3" BSP COLLAR	W001S	2	

Intentionally Left Blank

**7. APPENDIX**  
**Hydraulic Diagram**

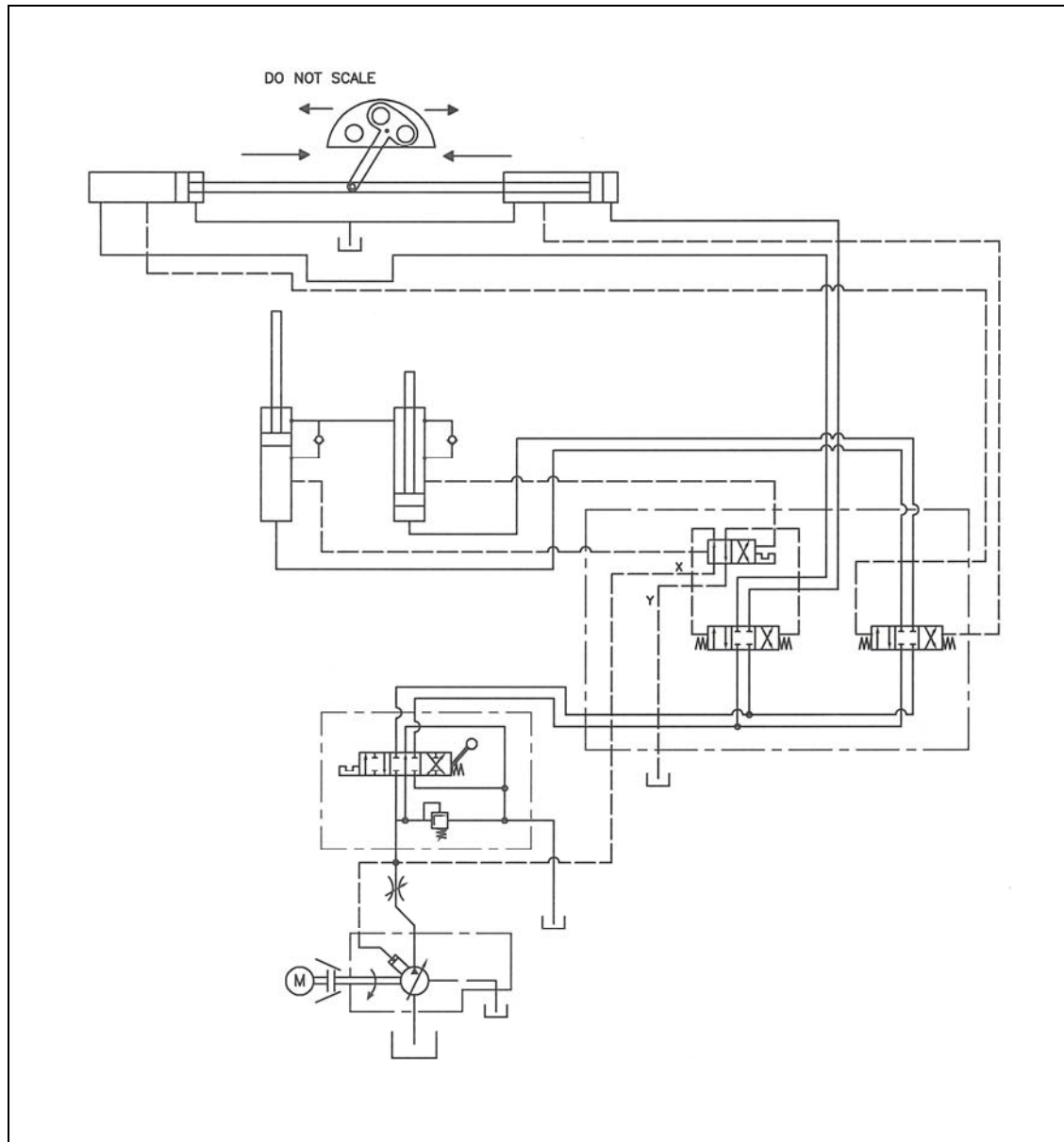

Intentionally Left Blank